



Fully-Automatic, Continuous-Motion Side-Sealer

SERVO JET 500

Smart Technology for more flexibility

Continuous motion side sealers for reliable and troublefree high-performance packaging. The innovative linkage of decentralized servo drives with a PC-based ELAU MAX 4 (Gen 3) control system results in high performance with an attractive pricing.

The decentralized and expandable system structure of the controller manages all programmable logic controller (PLC) functions as well as all movements in the machine with extreme precision and reliability. In conjunction with servo drive systems, this perfected PC-based technology provides highest flexibility for fast, smooth and high-quality wrapping of products. The processing speeds are considerably higher than those of traditional programmable logic controller (PLC).



Facts, data, figures

Technical Data

Min./max. product length:	80 mm / upon request
Min./max. product width:	50 mm / 400 mm
Sealing systems (cross-sealer):	Special coating, permanently heated, maintenance free, fast and easy exchangeable sealing ledge in different profiles for high-quality seals
Width of cross-seal bar:	550 mm
Max. clearance height of cross-sealer:	max. 200 mm
Operator interface:	colour Touchpanel
Control system:	PacDrive™ - with decentralized servo drives
Variable speed transport conveyor:	Up to 35 m/min. by the means of servo drives and frequency transformers
Film reel width::	max. 600 mm (centre-folded film) optional also flat film
Film reel outside diameter:	max. 400 mm
Min./max. width of film scrap:	15 mm / 100 mm
Power supply:	400 volts, 50 Hz, 3-phase, with protective earth conductor
Rated capacity:	max. 10 kVA
Nominal current (at 400 V):	14,5 A
Working height:	850 (adjustable \pm 50 mm)
Position of control panel and operating side:	Left hand side in working direction
Position of control cabinet:	Right hand side in working direction (rear side of machine)
Colour:	Kalfass anthracite

Your benefits by using our innovative technology:

Travelling cross-sealing system

Continuous side-sealing system

PacDrive™ from ELAU

operator interface and error diagnostic by colour Touchpanel (available languages: German, English, French) incl. Product Data Memory for various products

Compressed air not require

Machine dimensions (approx. in mm):

(This drawing may show options which are not included in the basic machine version and are available against up-charge only.)

Hinweis:
Kein Druckluftanschluß erforderlich!
Note:
No compressed air supply necessary!

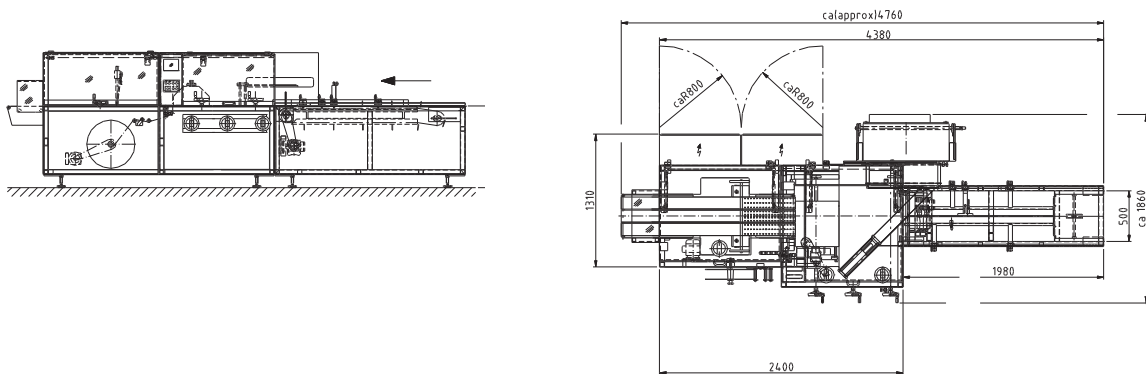

Kalfass Verpackungsmaschinen GmbH
Germany
Siemensstraße 8 · 72622 Nürtingen-Zizishausen
Phone +49/7022/607-0 · Fax +49/7022/607-200
info@kalfass.com · www.kalfass.com

