



## Fully-Automatic, Continuous-Motion Side-Sealer

# UNIVERSA 800 SERVO

### Continuous film packing of large formats

With the UNIVERSA 800 SERVO the success story of the Universa 500 Servo continues for the product range in larger formats. The "800 SERVO" offers new possibilities in packaging-speed and visual appearance with continuously **packing without STOP and GO**. There are no brake- or acceleration movements of the products during the packaging procedure. It is very important for heavy products which can be packed with higher speed.

The ingenious control program with SIEMENS® SIMOTION® and Servos gives more advantages to all product relevant drives, for example the electromotive servo-controlled height- and length adjustment of the cross sealing unit: after entering the product height – or the call of saved product details out of the Product Data Memory – the control calculates automatically the optimal height of the cross sealing bar and drives it to that point autonomous. Another advantage: the UNIVERSA SERVO models are optional available with automatically running-in of the transport belts above the sealing bar breach – without output losses! Just put **small parts** and screw bags to your furniture parts and they **will get safely transported and packed**.



**Kalfass**  
Verpackungsmaschinen

Results count.

## Facts, data, figures

### Technical Data

Packaging capacity due to product/film:	80 cycles/min.
width of cross seal bar:	850 mm
max. clearance in height of sealing frame:	250 mm
min. product length:	100 mm
operator interface :	Touchpanel SIEMENS
programmable logic controller (PLC)	SIMOTION from SIEMENS
sealing system:	permanently heated seal bar with exchangeable sealing ledge, maintenance free, with absolutely inodorous operation, temperature regulation by PLC
electromotive sealing bar drive:	servo-controlled
film:	centre-folded film, approx. 12 - 80 micron
film cradle	close to floor for easy film reel loading
outside diameter of film reel:	max. 400 mm
width of film reel:	max. 900 mm
speed of transport conveyor, variable:	10 – 35 m/min.
power supply:	400 volts, 50 Hz, 3-phase, with protective earth conductor
rated capacity:	6.0 kVA
nominal current (at 400 V):	8.7 amps
colour:	KALLFASS Anthracite

### Options at extra cost

film low control
perforating device with needle roller, 5 rows of needle
additional Gravity Pin Perforator Roller (1 roller with 8 pins)
integration of feeding systems (e. g. MGZ 400IL or transport conveyor) in PLC and product data memory
wheel/knife –combination (patent no EP 10224360.3) for fully closed sealing seams when processing multilayer, irradiated (electronically cross linked) co-polymer films
free rotating wear free counter seal bar for films without PP content (registered design)
wheel/knife –combination (patent no EP – 10224360.3) with separate cold-knife; for fully closed sealing seams when processing multilayer, irradiated co-polymer films)
vertical photo eye directly at the infeed of the machine for product sensing (instead of photo eye in the forming shoe) Note: observe transfer speeds!
vacuum transport belt for evenly film flow for challenging products
automatic closing of sealbar gap by in- and outfeed belt to assure safe transport of small products
side -inverted execution of machine (Note: check operating side of tunnel! Note: new V-type: V 244417)
light curtain in the machine infeed for detection of irregular products
print registration control (incl. mounting) vertically adjustable (print mark 100 % black)
double-layer tear-open perforation by cutting wheel for easy opening
electro-mechanical hole punching device for controlled air escape
integrated modem (Europe / world)
Ethernet-Interface (hardware), e.g. for connection to production server
machine on castors for mobility (differing working height!)
special colour (structure lacquer, monochromatic)
special voltage (for standard voltage see technical data)
special voltage (less than 380 volts) with line separation supply

### Machine dimensions (approx. in mm):

(This drawing may show options which are not included in the basic machine version and are available against up-charge only.)

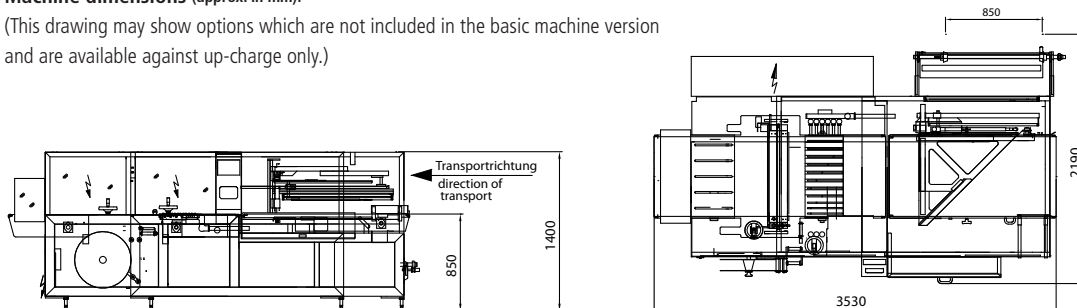

**Kallfass**  
Verpackungsmaschinen

**Kallfass Verpackungsmaschinen GmbH**  
Germany

Siemensstraße 8 . 72622 Nürtingen-Zizishausen  
Phone +49/7022/607-0 . Fax +49/7022/607-200  
info@kallfass.com . www.kallfass.com

