



Fully-automatic side sealer

UNIVERSA 800

For larger sizes

The UNIVERSA 800 is the perfect side sealer for larger products, such as picture frames, furniture, insulation material and others.

The **servo-controlled** seal bar is electromechanically driven (without mechanical brake) and guarantees an extremely smooth and low-wear packaging process. The seal bar pressure can be accurately adjusted. The encoder controls used by KALLFASS provide maximum flexibility and minimum change over times. Heavy-duty construction and well selected premium components assure the highest amount of runtime, even in tough multi-shift operation and with heavy products.

A wide range of options is available with the UNIVERSA 800, so it can be configured for many special applications. The optional modem and Ethernet connection make the UNIVERSA 800 the perfect component for fully automatic packaging lines, including with main server.



Facts, data, figures

Technical Data

Maximum production speed (depends on product and film used):	65 packs / min
Width of cross seal bar:	800 mm
Max. clearance in height of sealing frame:	300 mm
Min. product length:	120 mm
Film:	centre-folded or flat film, approx. 12 - 80 micron
Film cradle:	close to floor for easy film reel loading
Outside diameter of film reel:	max. 400 mm
Width of film reel:	max. 900 mm
Speed of transport conveyor, fix:	20 m/min
Sealing system:	servo-controlled seal bar, permanently heated seal bar with exchangeable sealing ledge, maintenance free, with absolutely inodoros operation, temperature regulation by PLC
Operator interface:	Touchpanel, SIEMENS TP 277
Programmable logic controller (PLC):	SIEMENS S7
Power supply:	400 volts, 50 Hz, 3-phase, with protective earth conductor
Rated capacity:	3,5 kVA
Nominal current (at 400 V):	5,1 A
Colour:	KALLFASS Anthracite

Controlling of the products by an encoder. Smooth readjusting of motion times on dimension-or speedchanges.

Infeed conveyor can be pulled out for better access during threading in film

Permanently heated seal bar with exchangeable sealing ledge, available in different profiles to produce excellent sealing seams depending on product and film

Operator guidance and error diagnostic by colour Touchpanel (available languages:

German, English, French – other languages upon request) incl. Product Data Memory for various products

Options at extra cost

Perforating device with needle roller, 5 rows of needles

Infinitely adjustable speed of both transport conveyors approx. 10 - 35 m/min, incl. smooth-start

Integration of feeding systems (e. g. MGZ 400IL or transport conveyor) in PLC and product data memory

Wheel/knife –combination (European Patent 1364769, German Part P 41703 EP/DE)

Clearance increased to approx. 330 mm

Vacuum suction conveyor belt for evenly film flow

Free rotating wear free counter seal bar for films without PP content (registered design)

Wheel/knife –combination (European Patent 1364769, German Part P 41703 EP/DE) with separate cold-knife

Outfeed conveyor as „kissing conveyor“ for small products (< 120 mm)

Tear-open perforation by cutting wheel for easy opening of packages

Integrated modem (Europe / world)

Ethernet-Interface (hardware), e.g. for connection to production server

Machine dimensions (approx. in mm):

(This drawing may show options which are not included in the basic machine version and are available against up-charge only.)

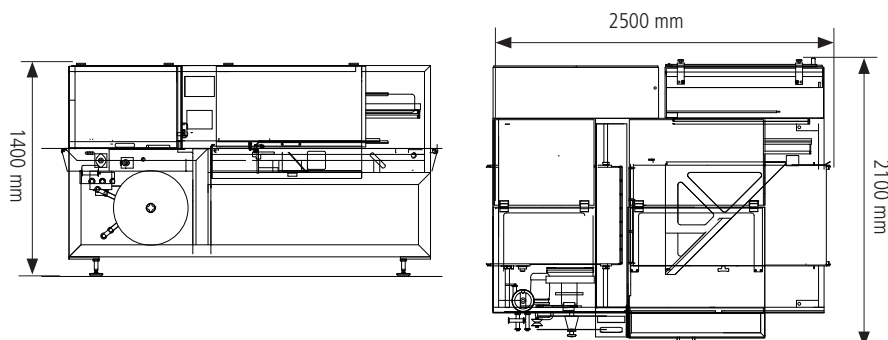

Kallfass Verpackungsmaschinen GmbH
Germany

Siemensstraße 8 . 72622 Nürtingen-Zizishausen
Phone +49/7022/607-0 . Fax +49/7022/607-200
info@kallfass.com . www.kallfass.com

